

Installation Summary

Ced'R Vue

To ensure the proper appearance and performance of the product, Maibec CanExel™ Engineered siding must be installed according to two key installation principles: adequate water evacuation and continuous wall ventilation.

This document outlines the key requirements for properly installing Maibec CanExel™ Engineered siding and trims. THIS DOCUMENT IN NO WAY REPLACES THE COMPLETE SIDING INSTALLATION, WHICH MUST BE FOLLOWED IN ITS ENTIRETY.

WALL PREPARATION

MAIBEC CANEXEL™ CAN BE INSTALLED HORIZONTALLY.

HORIZONTAL INSTALLATION

There must be an air barrier of at least 3/8" behind the siding. This air barrier can be obtained by using vertical furring strips through one of the following material:

- A. 1"x3" wood furring strip.
- B. Strip of treated OSB that are 3/8" thick and have a minimum width of 1.5".
- C. Ventilated strip made of sturdy plastic strip such as Cor-A-Vent « Sturdi-Strip ».

⚠ THE USE OF A SCREEN MAT OR DRAINAGE MAT SUCH AS A « SLICKER » IS STRICKLY PROHIBITED.

FIGURE 1

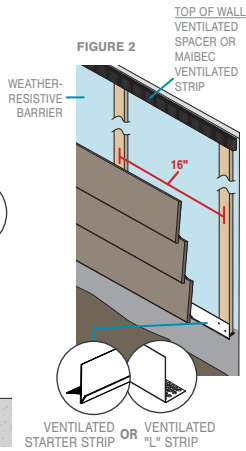
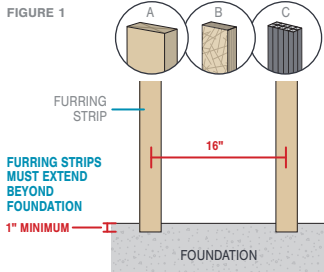

If Maibec Ventilated strip cannot be used, a ventilated spacer made of sturdy plastic strip such as Cor-A-Vent « SV-3 » is mandatory. To be used, the plastic strip must allow free vertical air flow of at least 45%.

Always make sure to have an air barrier of at least 3/8" behind the siding using vertical furring.

⚠ THE USE OF A SCREEN MAT OR DRAINAGE MAT SUCH AS A « SLICKER » IS STRICKLY PROHIBITED.

FIGURE 4

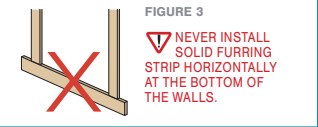
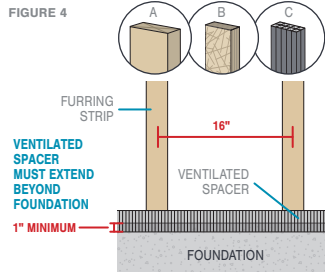
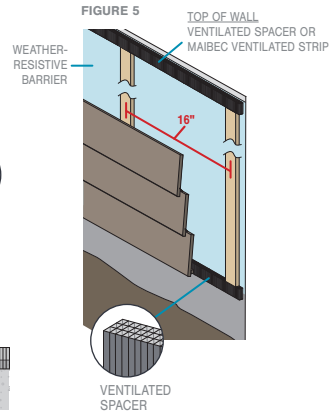

FIGURE 3
⚠ NEVER INSTALL SOLID FURRING STRIP HORIZONTALLY AT THE BOTTOM OF THE WALLS.

FIGURE 5



NAILING

- Maintain a minimum of 1 1/4" penetration into the stud, strapping, or combination of thereof.
- Secure the boards with one nail per furring strip every 16" o.c. maximum and at each end of the board.
- All exposed face nails must be properly sealed in a manner that prevents moisture intrusion and water buildup.

WITHOUT JOINT

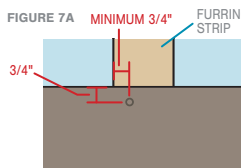

WITH JOINT

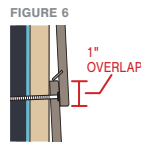
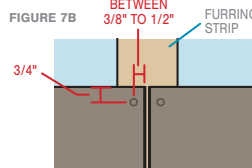

BOTTOM OF WALL PREPARATION AND STARTER COURSE

Install siding at least 6" from the ground. Siding should never come into direct contact with the ground or other surfaces.

HORIZONTAL INSTALLATION

FIGURE 8

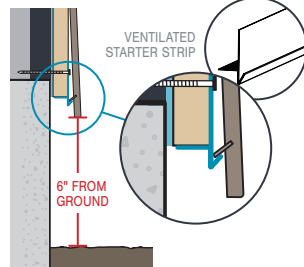
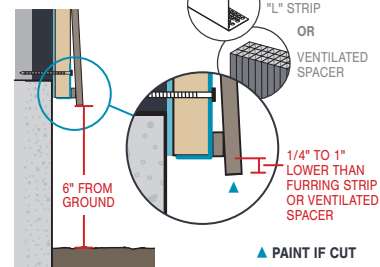

FIGURE 9



⚠ To ensure compliance and durability of the installation, the use of Maibec's ventilated starter strip is mandatory when a ventilated strip is required (installation on strapping) for horizontal installation, in accordance with the manufacturer's instructions.

CLEARANCES

FIGURE 10

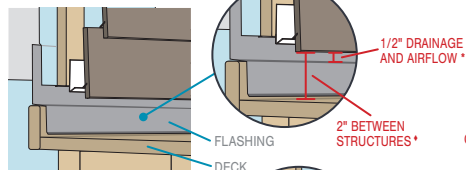

FIGURE 11

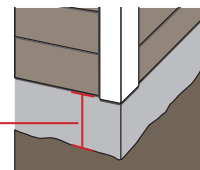
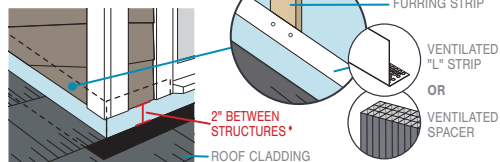

FIGURE 12



* The 1/2" spacing allow air to circulate and for heat to escape.
* The siding must have at least 2" clearance when it ends with other adjacent surfaces (roof, deck, slab) or according to the building code.

CONDITION	CORRECTION	INVISIBLE NAILS	VISIBLE NAILS
	OK		PAINT
	OK		PAINT
	PAINT		PAINT
	APPLY SEALANT.		APPLY SEALANT, THEN PAINT AND RE-NAIL.
	SEAL WITH CAULKING AND RE-NAIL.		APPLY SEALANT AND PAINT. RE-NAIL.

JOINTS

WITH SEALANT JOINTS

FIGURE 13

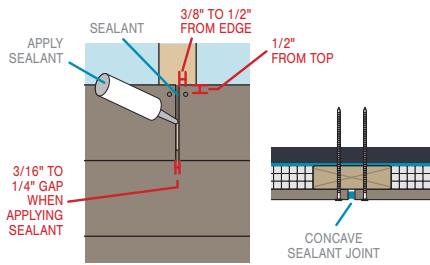

Joints must always occur over a furring strip and be centred.

WITH ALUMINUM JOINT MOLDINGS

FIGURE 14

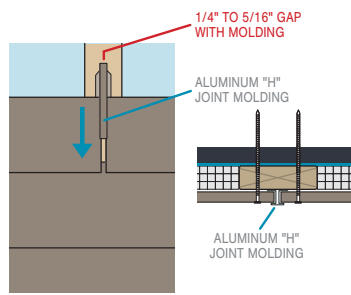

WITH DECORATIVE TRIM

FIGURE 15

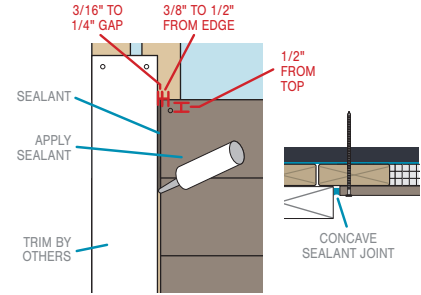

MOLDINGS AND ACCESSORIES

Moldings and trims must be installed to prevent moisture infiltration and water accumulation. Wood like moldings must be thick enough so that the siding does not exceed the level of their surface. Always keep a spacing between the siding and the accessories.

FIGURE 16

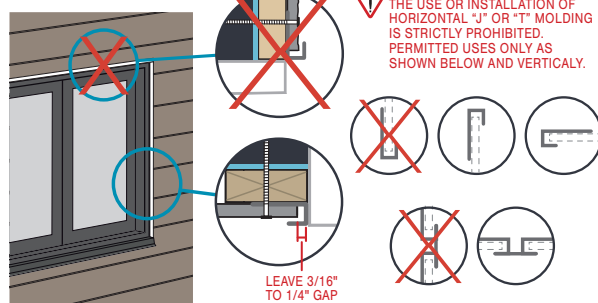

WINDOW HEAD VENTILATION

FIGURE 17

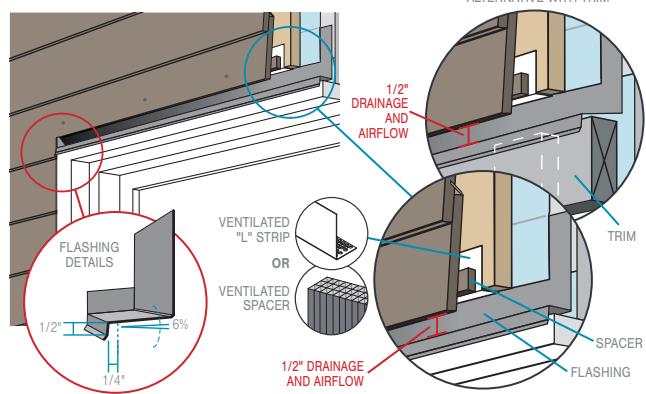

TOUCH-UPS

- TOUCH-UP BEFORE INSTALLATION.
- NEVER APPLY TOUCH-UP PAINT OVER NON-DAMAGED FACTORY COATED MATERIAL.

FIGURE 18

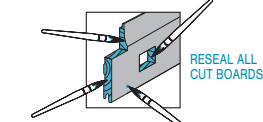
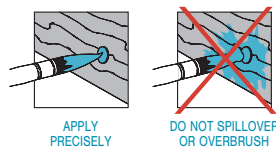

FIGURE 19



TOP OF WALL VENTILATION

VENTILATED "J" STRIP

FIGURE 20

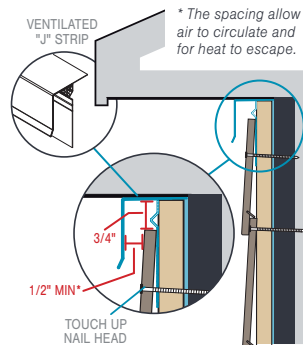

WINDOW SILL VENTILATION

WITH DECORATIVE TRIM

FIGURE 21

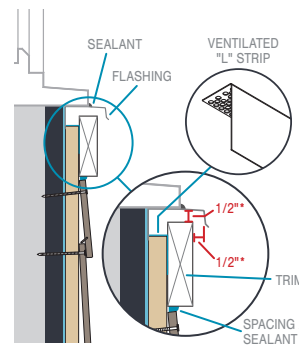

WITHOUT DECORATIVE TRIM

FIGURE 22

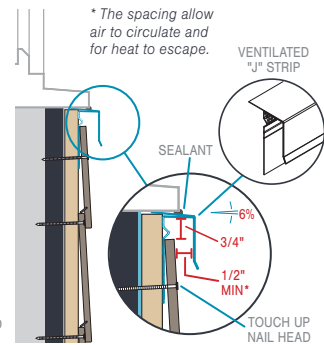

STORAGE

- Keep the siding in a dry, unheated, well-ventilated area away from the elements and at least 6" from the ground. Never let it come into direct contact with the ground.
- Cover any unused siding with its original packaging at all times, even during installation. If the original packaging is no longer in good condition, cover the siding with a waterproof tarp.
- Allow the siding to adapt to the weather conditions for 48 hours before installation.
- Touch-up paint should always be kept at room temperature (15°C or 60°F).

FIGURE 23

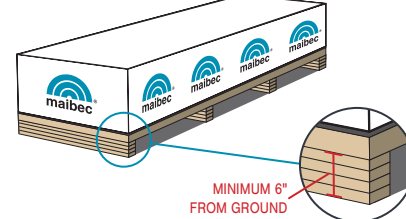

IMPORTANT: COMPLIANCE WITH MAIBEC'S INSTALLATION, STORAGE AND MAINTENANCE REQUIREMENTS, AND WITH ALL APPLICABLE BUILDING CODES IS MANDATORY. PROBLEMS CAUSED BY FAILURE TO COMPLY WITH THESE REQUIREMENTS AND CODES MAY NOT BE COVERED BY THE APPLICABLE WARRANTIES.